

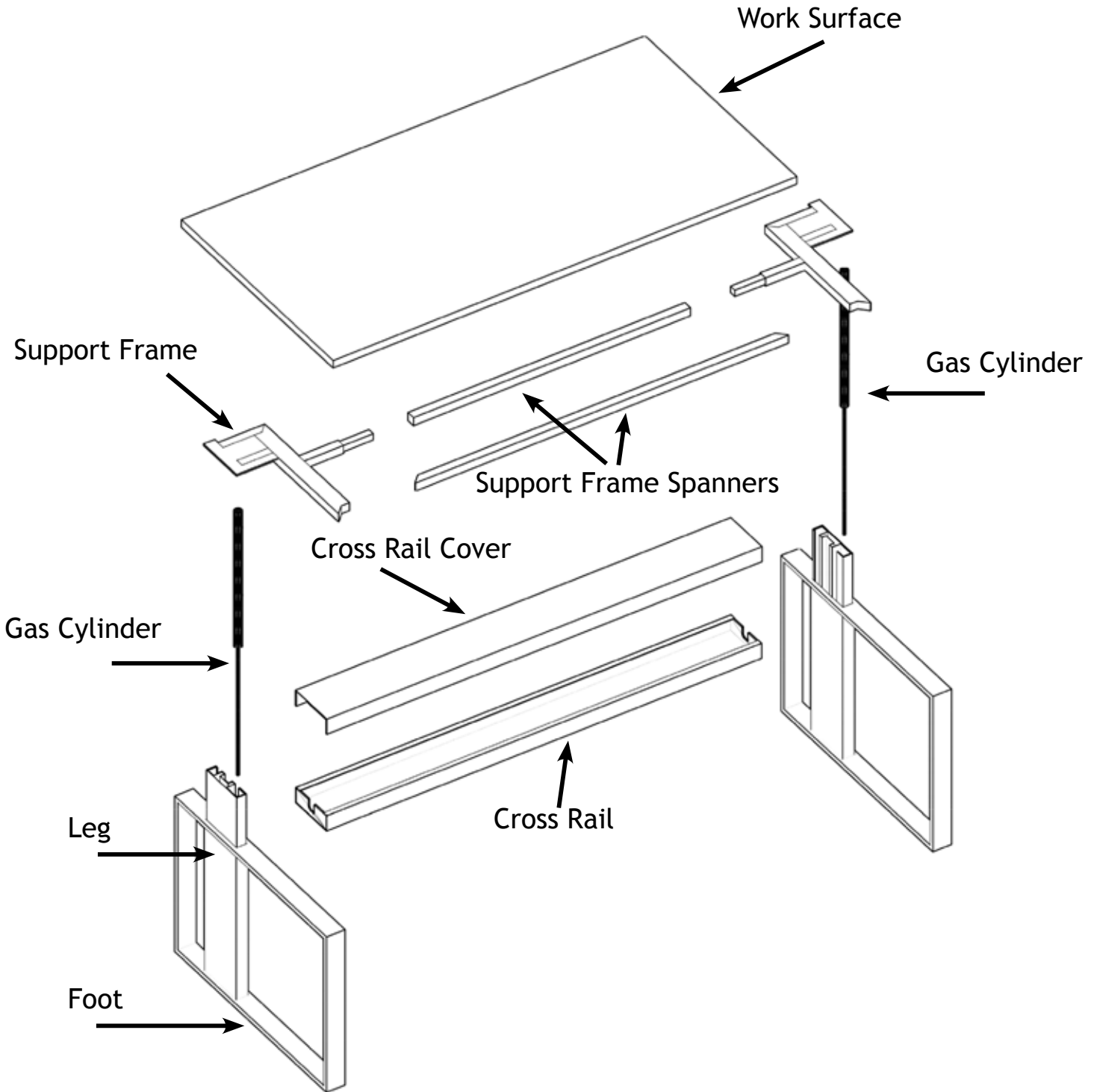

**iMove-F Assembly Manual
(Motorized Version-M1 /M2)**

Table of Contents

Exploded Desk Diagram	3	Section 2: Attaching the Lowboard/Pedestal	14
Hardware & Tools	4	Attaching Desk to Lowboard-Pedestal	15
Section 1: Basic Assembly of Desk Shipped “KD” (knock down)	5	Section 3: Accessories	17
Unpack and Identify Parts	6	Section 4: Care & Maintenance FAQ & Troubleshooting	19
Assemble Cross Rail to Columns	6	Section 5: Contact Us	24
Connecting Desktop Supports to Columns	8		
Assemble Work Surface Support Frame	9		
Attach Work Surface to Support Frame	10		
Replace Cross Rail Cover and Trim	11		
Attach Control Panel	12		
Leveling & Calibrating Desk	13		



pic.1

Tools and Hardware

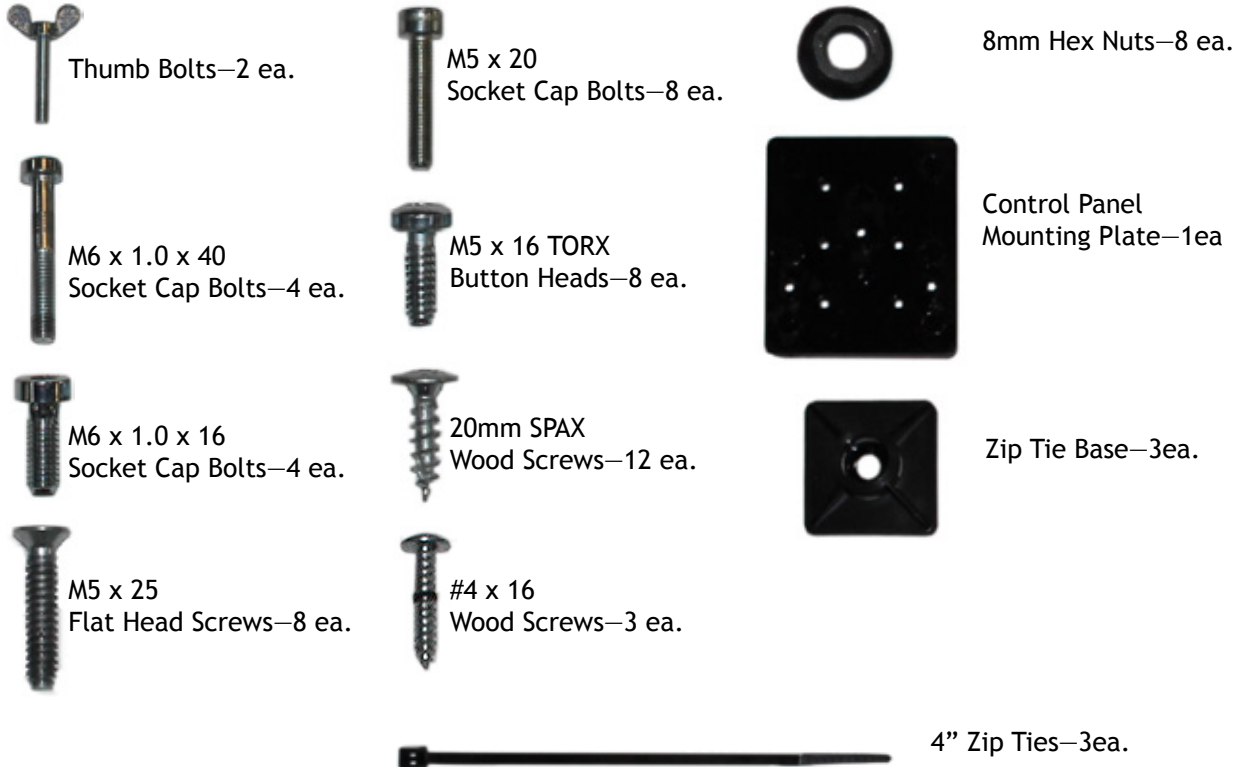
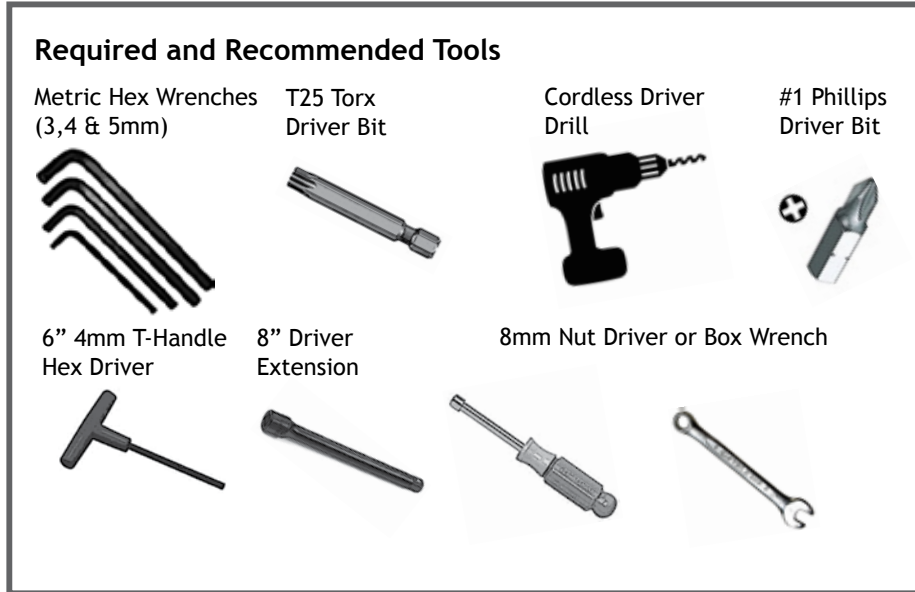

Section 1: Basic Assembly of Desk
Shipped “KD” (knock down)
-Motorized Version-M1/M2-

Basic Assembly of Desk Shipped “KD” (knock down)

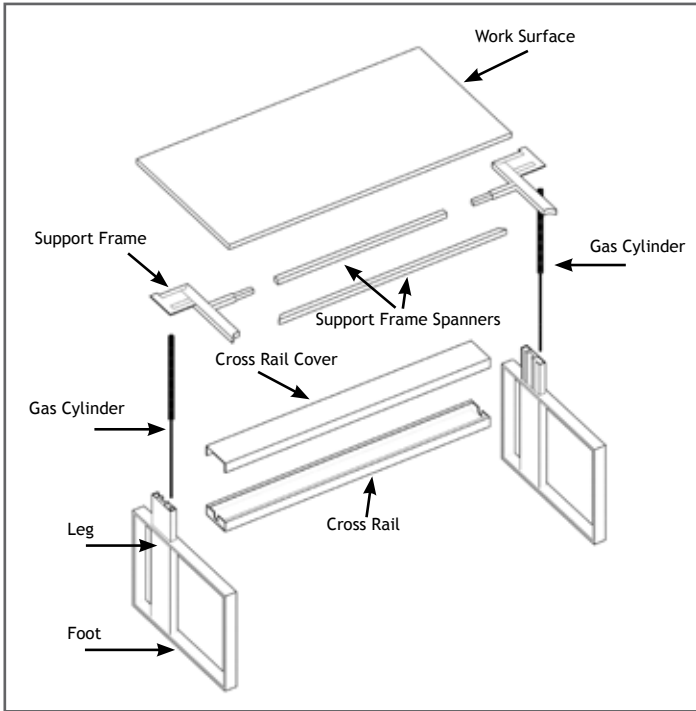

pic.1

1. Identify and uncrate ALL parts (pic.1)

NOTE:

1. Not all desks will require two gas cylinders. The number of gas cylinders will depend on the size and weight of desk top.

2. If user is providing their own custom top, determine the weight of the top and contact us to order the appropriate gas cylinders. (This step should have been completed at order entry).



Use caution when working with compressed gas cylinders. An uncontrolled release could cause severe damage and/or personal injury.



pic.2

2. Assembling Cross Rail to Columns (Legs)

- a. Use the 8mm nut driver or socket to remove cross rail cover at indicated positions. (pic.2-3)



cross rail as seen from below
pic.3

Basic Assembly of Desk Shipped “KD” (knock down)

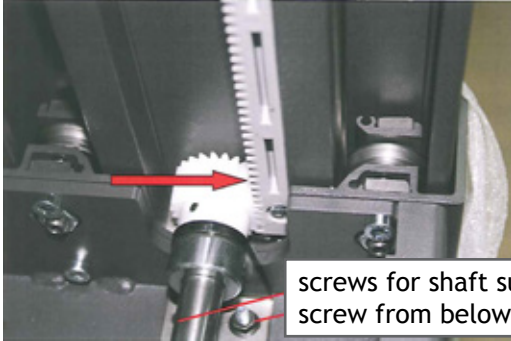

pic.5

2. Assembling Cross Rail to Columns (Legs) (continued)

c. Using the 3mm & 8mm wrenches, loosen/remove the two drive shaft support bracket bolts at each end of cross rail. (pic.5 & pic.6)

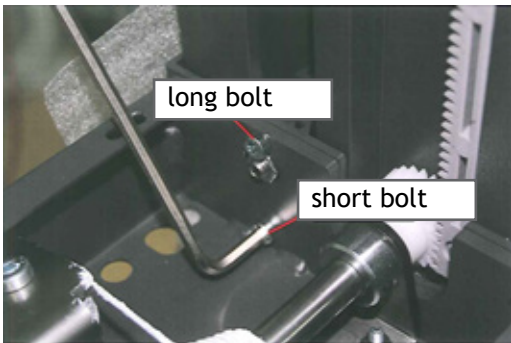

pic.6

d. With the “inner leg” FULLY extended join the cross rail to the leg and carefully insert the gear into the track. (pic.5) Make sure the inner leg is FULLY extended and the gear is properly engaged with the track.

***TIP:** The screw head at the end of the geared track should be aligned with the approximate center of the drive shaft/gear when the leg is at max height. (pic.7)



pic.7

e. Once cross rail is secured to legs, make sure the gear is seated with the geared track then tighten shaft support bracket bolts. (pic.8)



pic.8



CRITICAL!!! Make sure the gears in both columns (legs) are aligned at the exact same position in each gear track per above *TIP and picture 7.

Basic Assembly of Desk Shipped “KD” (knock down)

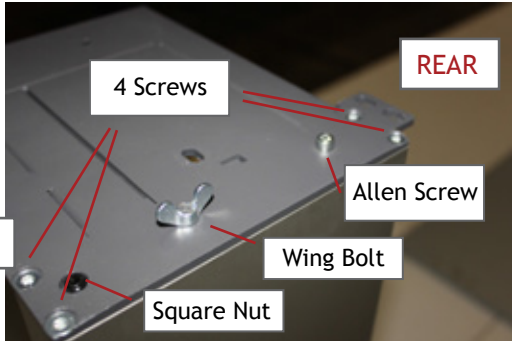

pic.9

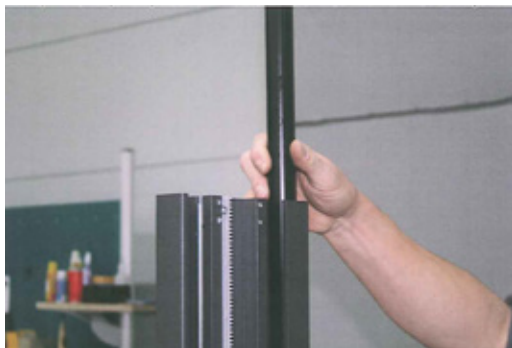

pic.10



pic.11

3. Connecting Desktop Supports to Columns

a. Use a T25 Driver and 4mm Hex Drive to remove top cover plate from leg assembly. (pic.9)

b. Install gas cylinders as shown (piston down) (pic.10)

Screw the cylinder piston into bottom plate. (hand tight)

c. Re-install support plate to column with four torx-screws, each using the outermost holes. (pic.9)

Screw in Allen screw. Screw in wing bolt by hand until hand-tight. Wings must be parallel to outside edge. (pic.11)

DO NOT remove square nut at the end of the cylinder. It should be screwed down completely on the cylinder and be UNDER the cover plate once assembled. (pic.11)



DO NOT attempt to operate desk once the gas cylinders are installed and before top is attached. The force of the cylinders without the weight of the top could damage the desk mechanism.

Basic Assembly of Desk Shipped “KD” (knock down)

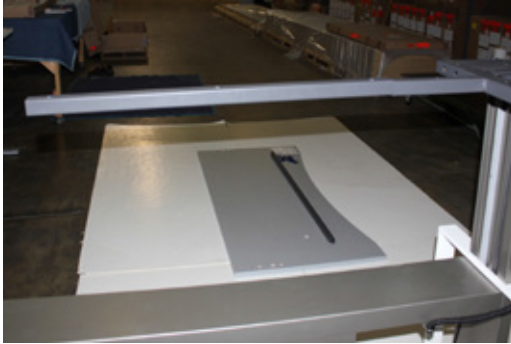

pic.12

4. Assemble Work Surface Support Frame

- a. Install spanner tubes between support plates with the larger diameter access holes facing down before attaching plates to top of legs. (pic 12)
- b. Secure support frame to inside of columns with 4 bolts. (pic 13)



pic.13



WARNING! Examine underside of worktop. Make sure “drillings” match top drawings. Top MUST fit flush on work surface support frame. If accurate proceed to Step 5.

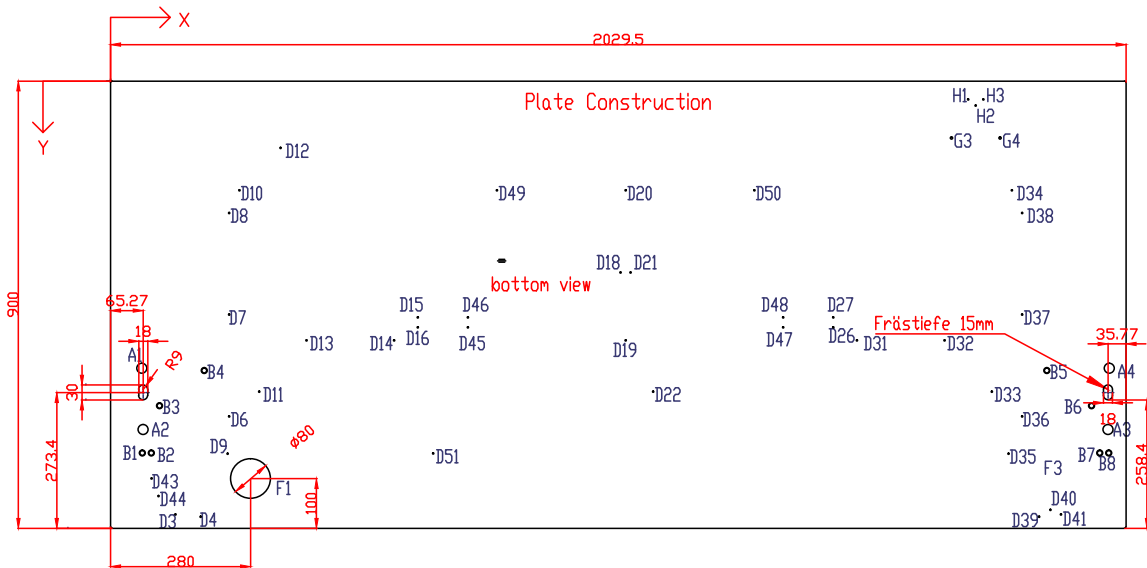

Generic Drilling Diagram
(your diagram may be different)

Basic Assembly of Desk Shipped “KD” (knock down)



pic.14

5. Attach Work Surface to Support Frame

a. Be sure the wing nut at the top of each leg is parallel with the side of the leg so it will align with the pre-drilled recess in the work surface (pic.14)

b. Place Desktop on floor with drillings visible. Flip Frame upside down and align holes to drillings. (pic.15)

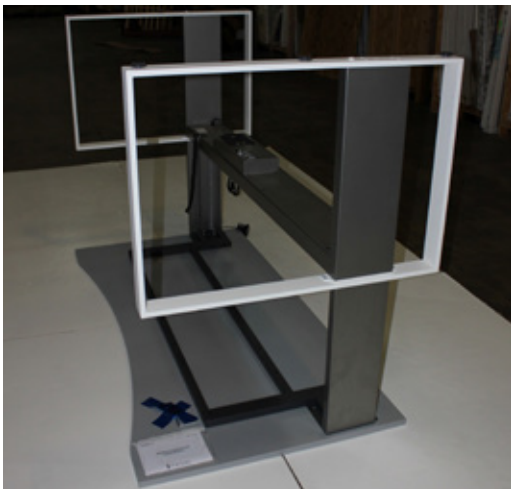

pic.15

c. Align the threaded inserts with holes in the support plates. Use the 8 bolts provided to attach the work surface. (pic.16)



WARNING! The iMove Series uses a variety of top thicknesses. **VERIFY** length of wood screws are appropriate for the thickness of the top prior to fastening

d. Use wood screws to secure the rest of the frame to the top. (pic.17)

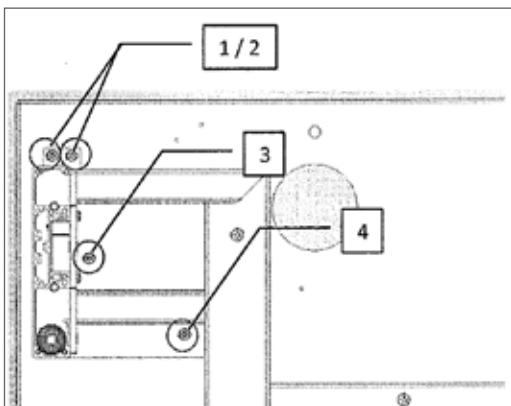

pic.16

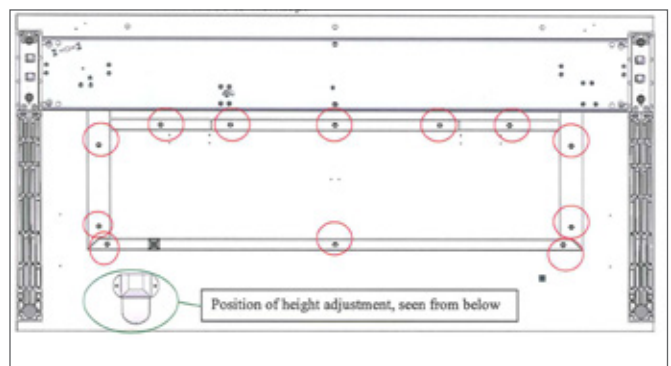

pic.17

Basic Assembly of Desk Shipped “KD” (knock down)

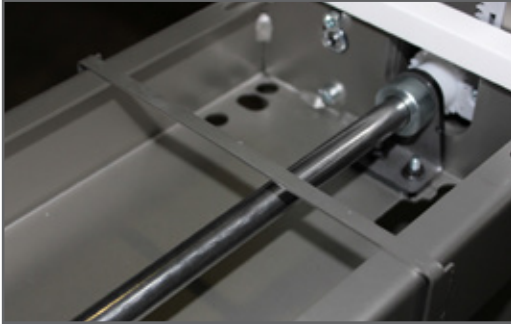

pic.18

6. Replace Cross Rail Cover and Trim (as shown). (pic.18, 19, 20 & 21)

a. Slide trim piece into position (pic.18-19)

b. Align cover on top of cross rail

c. Screw cover to cross rail using the 8-8mm hex nuts removed in Step 2. (pic.20)

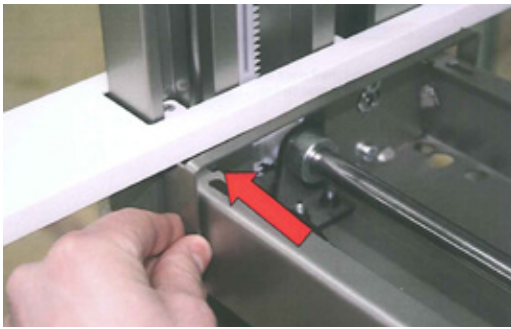

pic.19



pic.20



cross rail as seen from below

pic.21

Basic Assembly of Desk Shipped “KD” (knock down)

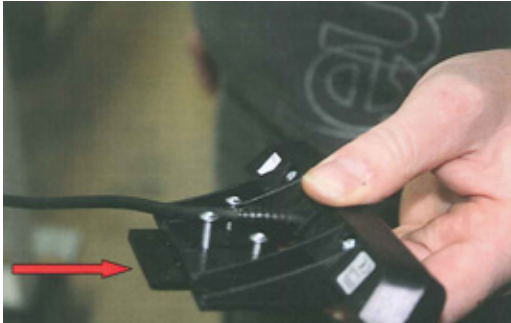

pic.22

7. Attach Control Panel

- a. Locate the pre-drilled holes on the underside of the work surface.

Use a #1 Phillips Drive bit.

- b. Once mounted, Control Panel should slide in & out approximately 1” (do not over tighten). (pic.23)



pic.23

- c. Attach cord to the underside of the desk so that it hangs vertically from the cross rail (pic.24)

NOTE:

If Desk is integrated into a lowboard/pedestal jump to Section 2/page 15, install lowboard-pedestal before moving to Step 8.

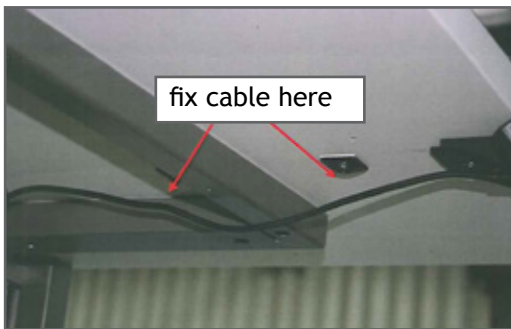

pic.24



M1 Control Panel



M2 Control Panel

Basic Assembly of Desk Shipped “KD” (knock down)

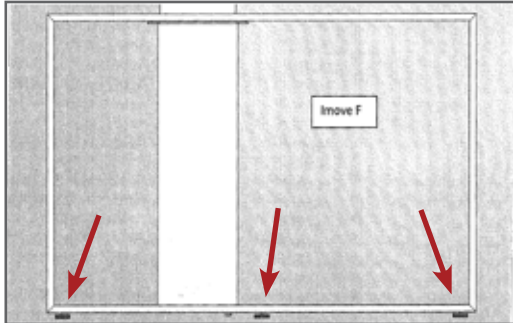

pic.25

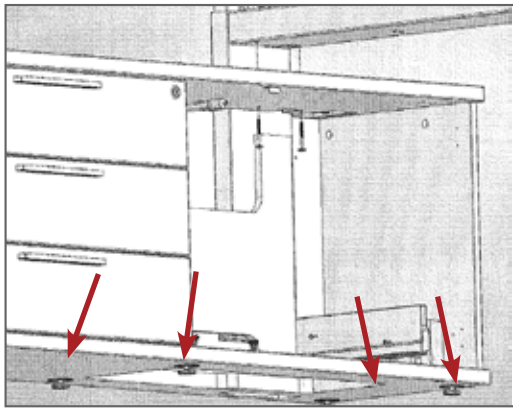

pic.25a

8. Leveling and Calibrating Desk

- a. Level Desk horizontally using the 3 leveling glides on each leg frame. (pic.25)
- b. If Lowboard/Pedestal on one side, level Lowboard to leg frame using glides indicated in pic.25a

Calibrating Desk

Plug desk into standard 120V grounded power supply.

When the desk is plugged in for the first time (or after power is interrupted) the control panel will flash “000” continuously.

Regardless of the position (height) of the top, the following reset procedure must be performed before the desk will be fully functional.

1. With the desk plugged into a standard power outlet (**M2 only-control panel IS illuminated and flashing “000”**), press and hold the down arrow on the control panel.
2. Hold the down arrow until the desk reaches lowest position and stops.
3. For M1-Hold the down arrow at lowest position for 3 seconds. (**M2 only-Continue pressing the down arrow until the LED stops flashing and reads “68”**).
4. The desk is now ready for use.



If desk makes any unusual sounds or does not operate smoothly throughout its FULL Range of motion, STOP IMMEDIATELY, refer to Section 5 and call coronaDESKING at once.

Section 2: Attaching the Desk to the Lowboard/Pedestal

Step by Step Assembly Instructions

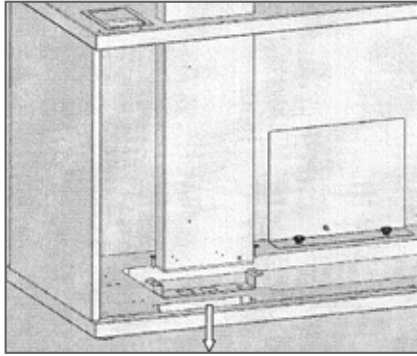

pic.26

9. Attaching Desk to Lowboard/Pedestal

- a. Attach the support plate using two Spax Screws (pic.26)
- b. Lift the entire desk to provide a straight entry for the leg. Then carefully Insert the table leg into the provided cut-out in the lowboard/ pedestal and seat leg into the recessed support plate. (pic.26 & 27)
- c. From inside the lowboard/pedestal bolt the cross rail to the top of the lowboard-pedestal. (pic 28 & 29)

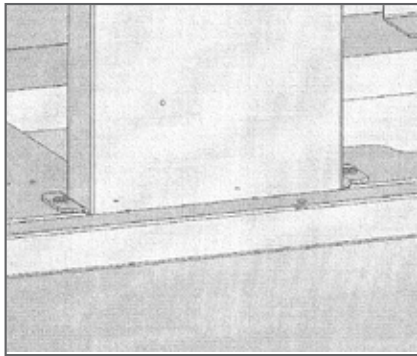

pic.27

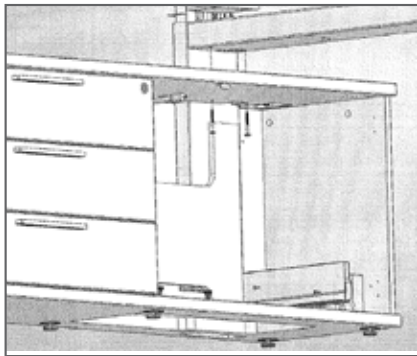

pic.28

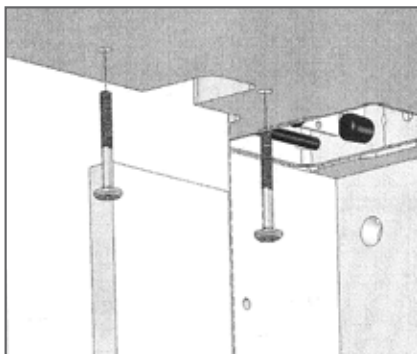

pic.29

Step by Step Assembly Instructions

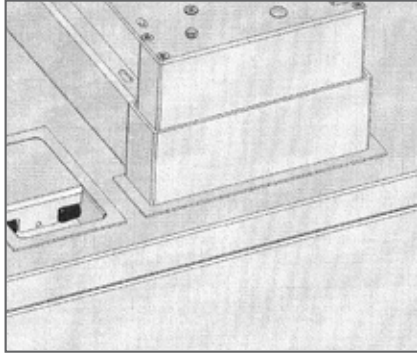

pic.30

9. Attaching Desk to Lowboard/Pedestal (cont.)

d. Install U-Shaped metal trim piece around column (leg). (pic.31)

e. Install Cable Access/Ventilation Plate into corresponding cut-out. (pic.32)

f. Install Cable Chain to underside of Desk Top above the lowboard/pedestal. (pic.33)



pic.31

NOTE:

Position mounting bracket for Cable Chain at 90° angle prior to fastening.

Raise Desk to highest position. Allow length of Cable Chain to enter lowboard/pedestal 2". Remove any excess Cable Chain from interior of cabinet.



pic.32

Section 3: Accessories



Free Standing Cable Chain
See instructions included in the Accessory Box



Cable Bows
See instructions included in the Accessory Box



Desk Top Grommet
If not factory installed, install using templates and instructions provided.



Desk Top Data/Power Module
If not factory installed, install using templates and instructions provided.

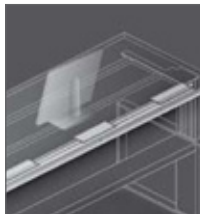

Cable Tray
See instructions included in the Accessory Box



Desk Top Privacy Panel
See instructions included in the Accessory Box



CPU Holder

Section 4: Care and Maintenance FAQ & Troubleshooting

Care & Maintenance

1. Cleaning—

Soft damp cloth only.
No solvent based or abrasive cleaner.

***TIP:** When cleaning a wood veneer surface, always wipe “with the grain” to avoid creating any visible scratches.

2. Lubrication—

Every desk should be fully lubricated at the factory. Should additional lubrication be required, apply a small amount of lithium grease as needed. Only apply lubricant to “moving” parts within the cross rail. Excess lubricant on exposed surfaces of the desk should be cleaned with warm soapy water and a soft cloth.

FAQ & Troubleshooting

1. How much weight can I put on the top of the desk?

The typical desk is set up to safely handle up to 165 lbs. of additional weight.

2. How do I reset the controls when the power goes out?

If the power is interrupted the LED readout on the control panel will flash “000” continuously (**M2 only**) .

Follow these reset procedures:

1. With the desk plugged into a standard power outlet (**M2 only-control panel IS illuminated and flashing “000”**), press and hold the down arrow on the control panel.
2. Hold the down arrow until the desk reaches lowest position and stops.
3. For M1-Hold the down arrow at lowest position for 3 seconds. (**M2 only-Continue pressing the down arrow until the LED stops flashing and reads “68”**).
4. The desk is now ready for use.

***NOTE:**

The desk will only move down at a safe speed until the reset procedure is successfully completed.

3. Adjustments & Calibration–

M1/M2 Sit-Stand Adjustment

Static *loading max.	265 lbs (120 kg)
max load-M1/M2	0-165 lbs (0-75 kg)
movable *load option-ZM (M1/M2)	min 88 lbs (40kg)-max 253 lbs (115 kg)

*load = additional weight equally distributed on the desk top.

 FAQ & Troubleshooting

Error	Cause	Rectification
Desk does not move	No electrical power supply	Check-if power socket supplies electrical potential, power cable
	Max. additional load—exceeded according to the technical data	Reduce weight
	Min. additional load—undershoot according to the technical data (option ZM)	Put min. weight bearing on desk top
	Max. power-on time exceeded	Control reactivates after approx. 9 minutes automatically
	Defective Drive	Contact Customer support
	Defective Control Panel	Contact Customer support
Desk is slowly moving downward	Control expects new initialization	See Page 21
Desk is moving upwards shortly and stops	Max. additional load exceeded	Reduce weight
Desk is moving downwards shortly and stops	Min. additional load undershoot	Put min. weight bearing on desk top

FAQ & Troubleshooting

Error Messages in the Hand Switch Display-M2 Option

Error	Cause	Rectification
Hot	The control monitors the power-on time (time controlled) and their max. temperature. A value has been exceeded	Wait until advice “hot” no longer appears on display. Desk should work correctly.
E01	M1-Relay defect	Pull power plug! Contact Customer Service
E02	M2-Relay defect	
E06	M1-MOS FET defect	Pull power plug! Contact Customer Service
E07	M1-MOS FET defect	
E11	Short circuit on M1	Pull power plug! Check Cable to motors and clear short circuit
E12	Short circuit on M2	
E29	Impluse Timeout-M1	There might be an overload: up-remove excess weight on desk top down-remove excess weight on desk top
E30	Impluse Timeout-M2	
E67	MOS FET-Temperature	Wait until advice “hot” no longer appears on display. Desk should work correctly.
E68	Detector-Temperature	
E69	Internal error	Pull power plug! Contact Customer Service
E44	Overcurrent on M1	There might be an overload: up-remove excess weight on desk top down-remove excess weight on desk top
E45	Overcurrent on M2	
E54	Overcurrent on control	
E70	Overcurrent on motor group	

Section 5: Contact Information



For additional technical information and help,
contact the following:

Installations-

Greg Hutchens

c 205.902.6164

greg.hutchens@coronagroupinc.com

Customer Service-

Alicia Burrow

p 205.329.7057 (direct)

alicia.burrow@coronagroupinc.com



where custom is standard

205.941.1942

Birmingham, AL

info@coronagroupinc.com

coronagroupinc.com